

# RM33 & 52

## Relative Humidity and Temperature Transmitter, HVAC Room Mount



The RM series of relative humidity and temperature transmitters offers a comprehensive range of output signals and measurement ranges. The transmitters are housed in a wall mounted enclosure, making these instruments ideal for HVAC and building management applications.

### Highlights

- Designed for low cost HVAC applications
- Quick installation: electrical rear connection with screw terminals
- Superior long term stability

### Technical Specifications

Performance	
Measurement range (RH)	0–100% RH
Measurement range (T)	32 to 122°F / 0 to +50°C Pt100, Pt1000
RH Accuracy at 23°C / 73°F	RM52: <math>\pm 2\%</math> RH (10–90% RH) RM33: <math>\pm 3\%</math> RH (30–80% RH)
Temperature Accuracy	RM52: $\pm 0.2^{\circ}\text{C}$ (-10 to +50°C) $\pm 0.36^{\circ}\text{F}$ (14 to 122°F) RM33: $\pm 0.3^{\circ}\text{C}$ (5 to 40°C) $\pm 0.54^{\circ}\text{F}$ (41 to 104°F)
Temperature influence	$\pm 0.027\%$ RH/°F / $\pm 0.05\%$ RH/°C
Stability – RH Sensor	$\pm 1\%$ RH/year
Response time – RH Sensor	<10 sec typical (for 90% of the step change)
Electrical output/input	
Output signal	0–1 VDC, 0–5 VDC, 0–10 VDC 4–20 mA (2-wire)
Supply voltage	14–35 VDC (for 0–5 / 10 VDC 4.5–35 VDC (for 0–1 VDC) and 14–26 VAC
Supply voltage influence	$\pm 0.01\%$ RH/V typical
Operating conditions	
Operating humidity	10–90% RH Probe, Housing, Storage
Operating temperature	Electronics: 32 to 125°F / 0 to +50°C Storage: -40 to +170°F / -40 to +75°C
PRT	
Measurement range	Pt100/1000: -60 to +390°F / -50 to +200°C
Accuracy	Pt100/1000: $\pm 0.15\%$
Mechanical specification	
Ingress protection	N/A
Housing material	White molded polymer housing
Dimensions	3.58 x 3.58 x 1.00 inches / 91 x 91 x 25.5 mm
Filter	N/A
Weight	3oz / 85g
Electrical connections	Screw terminals

# RM33 & 52

## Dimensions

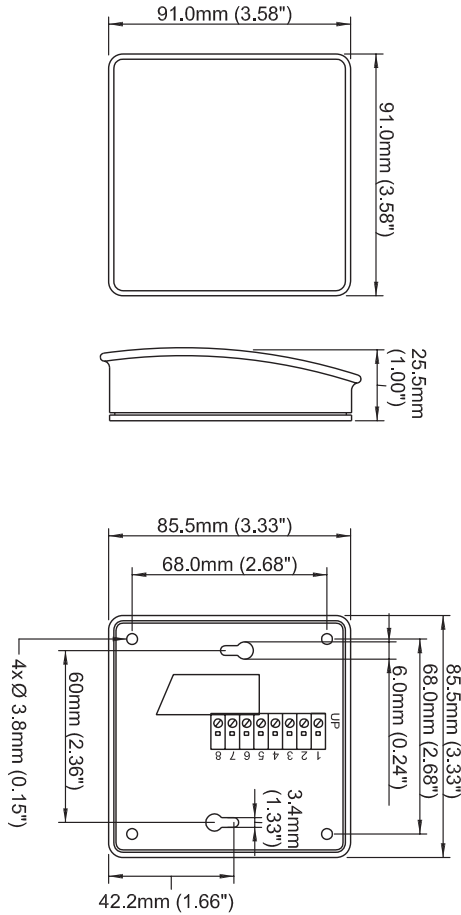

## Electrical Connections

Voltage output	
Pin 1	Pin 1
Pin 2	Pin 2
Pin 3	Pin 3
Pin 4	Output temperature
Pin 5	Output RH
Pin 6	Common ground
Pin 7	Power supply V+
Pin 8	

Temperature sensor  
Pt100/Pt1000

Humidity with temperature sensor

mA output	
Pin 1	Output RH +
Pin 2	Output RH -
Pin 3	
Pin 4	
Pin 5	
Pin 6	
Pin 7	
Pin 8	

Temperature sensor

Humidity with temperature sensor

## Order codes

Relative humidity and temperature transmitter

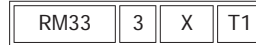

Accuracy configuration	
3% accuracy	RM33
2% accuracy	RM52

Output configuration	
4–20 mA analog output	2
0–10 V analog output	3
0–5 V analog output	4
0–1 V analog output	5

Temperature output range and configuration	
No temperature output, RH signal only	X
32 to +122°F / 0 to 50°C (Available with voltage output only)	T3
Pt100: -60 to +390°F / -50 to +200°C class A	T4
Pt1000: -60 to +390°F / -50 to +200°C class A	T5
Other output scaling on request	TX

### Example: RM33 3 X T1

Relative humidity and temperature transmitter RM33, HVAC 3% accuracy, 0–10V analog output, and -4 to +176°F / -20 to +80°C temperature range.

Please note: Michell Instruments adopts a continuous development program which sometimes necessitates specification changes without notice. Please contact us for latest version. Ref: RM33&52\_1001US\_P



Process Measurement & Controls, Inc. Email: sales@pmc1.com  
 Michell Instruments RH Web: www.michell.com/us/rh  
 11 Old Sugar Hollow Road Tel: 203-792-8686  
 Danbury, CT 06810 USA Fax: 203-743-2051

Represented by: