



PAPER MACHINE COMPONENTS, INC.

MIRY BROOK ROAD, DANBURY, CONNECTICUT. 06810

Telephone: (203) 792 8686

P.M.C. LEVEL TRANSMITTER INSTALLATION & OPERATING DATA

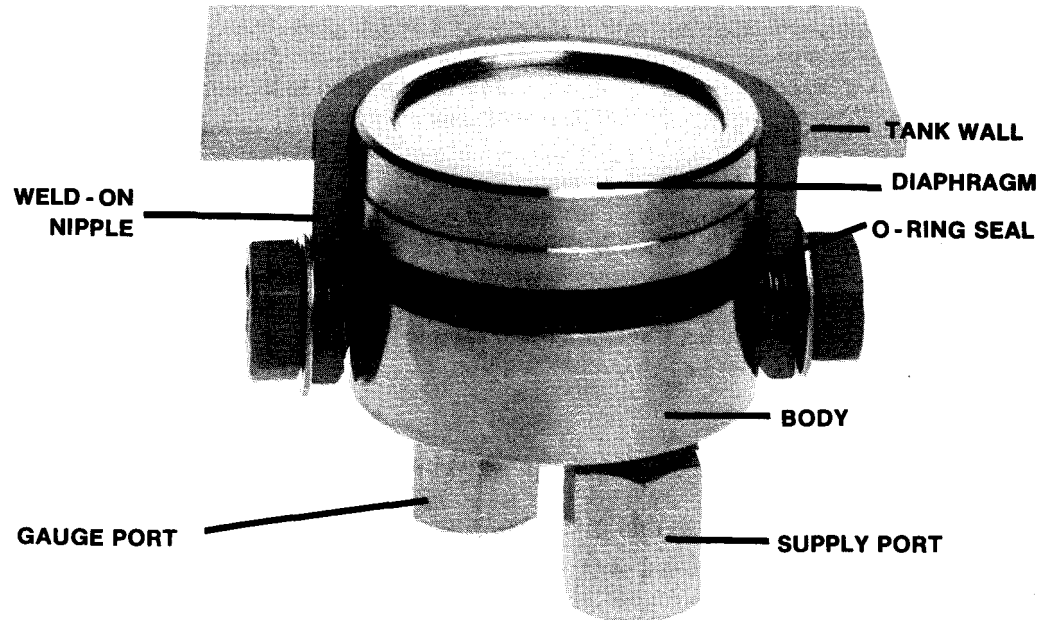

(1) CUT HOLE FOR NIPPLE

Drill or cut a hole slightly smaller than the nipple outside diameter (1-7/8"), in the side or bottom of the tank where the transmitter is to be located. The hole should be close to a flange or opening so that the inside wall of the tank can be cleaned up after the nipple is welded in place. File the hole so that the stainless steel nipple fits tightly in the hole. The fit must be snug otherwise the nipple will cock when it is welded in place. Some customers have made up a collapsing internal steel mandrel, and slipped it into the nipple during the weld operation. This helps prevent distortion of the nipple.

NOTE: Marvel* or similar hole saws 1-7/8" O.D. (48mm) may be used with a slow speed drill (100 RPM) to cut out the proper size hole. The saw teeth should be continuously cooled while cutting the hole with a water soluble cutting oil such as Rustlick WS-500. (*Armstrong-Blum Mfg. Company, 5700 W. Bloomingdale Avenue, Chicago 39, Illinois, manufacture Marvel hole saws.)

Hole saw kit LT-HSK is available from stock. It includes a ground Marvel hole saw, mandrel, drill, guide dowel, SCR speed control, cutting oil concentrate, applicator and case. Needs 1/2" electric drill.

(2) WELD NIPPLE IN PLACE

Position the nipple and transmitter with set screw installed, into the hole so that the diaphragm on the transmitter is flush with the inside wall of the tank. Mark the nipple both inside and out. On small diameter pipes (4" and less) the nipple and transmitter will protrude into the pipe due to crown of the pipe. **(The transmitter must be removed from the nipple before welding.)** Weld the nipple in place with either Heliarc (inert gas arc process) or with arc and stabilized 316 stainless steel rods. This will prevent carbide precipitation and subsequent corrosion at the weld.

(3) GRIND NIPPLE FLUSH

Finish grind the nipple flush with the inside of the tank. Clean up the inside edge of the nipple at the tank end with a fine half-round file. Remove all burrs but do not make any ridges or grooves on the inside nipple wall, otherwise material inside the tank will leak past the O-ring seal.

(4) **INSTALL TRANSMITTER**

Capsules of Dow Silicone grease (Valve Seal) are furnished with each order. Apply a thin wipe to the O-ring, diaphragm ring, edge of the nipple, and the remainder to the inside wall of the nipple at the bottom end where it connects into the pipe wall. The purpose of applying silicone grease at this point is to prevent galvanic cell corrosion between the diaphragm ring and the nipple wall. Silicone grease is stable from -40°F to 500°F and does not readily dissolve. Install the transmitter and locate with set screws. The transmitter diaphragm should be flush with the inside wall of the pipe if the nipple was properly positioned in the first place.

NOTE: Avoid contact with the eyes when using silicone grease.

(5) **CONNECT SUPPLY AIR**

Connect dry filtered air to the SUPPLY port. The standard transmitter has been calibrated with 20 PSIG (1.5 ATMOSPHERE) supply air and consumes approximately 2.5 standard cubic feet of air per hour. It will also operate at any specified range providing supply air 5 PSIG (0.35 ATMOS.) greater than the maximum reading desired is available. The air must be clean and dry otherwise the flow control needle will become plugged and fail to operate. **A 2" supply pressure gauge should be connected to the supply line** to ensure that the flow control valve and transmitter are being supplied with adequate air pressure.

(6) **MAKE GAUGE CONNECTION**

Connect a pressure gauge, manometer or recorder to the GAUGE port. If remote operation is desired, readings up to 100 feet away may be obtained if continuous 50 foot lengths of ¼" O.D. copper tubing are used (we say continuous because this avoids connections which invariably are not tightened and therefore leak, and the transmitter does not yield proper readings). **Special care must be taken to tighten all connectors and use thread seal on all pipe connections between transmitter and remote indicator or recorder, in order to avoid air leaks.** Leaks can be detected with children's soap bubble solution.

(7) **TURN ON AIR SUPPLY**

Turn on the air supply. Air should exhaust at a slight rate from exhaust port.

(8) **ADJUSTMENTS TO FLOW CONTROL VALVE**

Normally, there is no need to make any adjustment. The flow control valve has been set approximately ½ turn open to deliver 2.5 SCFH (standard cubic feet per hour). A rota-meter-taper flowmeter, part PMC-FML @\$8.00 may be used for checking proper flow rate. If better response is required, be sure to check for air leaks in the connecting tubing with a soap bubble solution before making any adjustments to the needle valve. **Excess use of air and unsatisfactory operation will occur if the needle valve is opened beyond ONE FULL TURN.** The factory setting is marked in line with the needle valve slot.

(9) **LOW READINGS**

If gauge readings appear low, close the needle valve then re-open approximately ½ turn to point where the slot lines up with the calibration vee mark. This action clears residual carbon and oil gum and restores proper air flow through the transmitter.

ADDITIONAL INFORMATION

- Do not use a pipe wrench on the body of the transmitter during installation. The fit between nipple and transmitter should be free enough to permit installation and removal by hand. Avoid excessive clearance.
- Avoid excess use of thread seal, otherwise the gauge connection and supply connection filter discs may become plugged and prevent the transmitter from operating properly.
- PVC DUMMY TRANSMITTERS — One or more dummy transmitters are furnished to each user. They can be substituted for regular transmitters in case repairs or changes are necessary. Additional PVC dummies are available from stock.
- The transmitter body O-ring may be removed with a scribe or small screw driver.

ADDITIONAL INFORMATION (continued)

- **EXHAUST SILENCER:** A silicone sleeve has been pressed into the 1/8" exhaust port. The silencer is equipped with a .052"D hole to limit transmitter exhaust rate, thereby eliminating undesirable exhaust whistle.
- **SERIAL NUMBER:** Each transmitter is marked on the end opposite the diaphragm. Please refer to this number when ordering parts.
- **EXTREMELY IMPORTANT:** A white cap has been installed over the diaphragm to protect it during shipment and installation. **Keep this cap in place until the final tubing connections have been made.**
- **DIAPHRAGM REPLACEMENT:** *Replacement diaphragms are available only as BONDED ASSEMBLIES, and consist of retainer ring, diaphragm bonded in place, and inner O-ring. These assemblies provide long term dependable readings, eliminate the possibility of blow out and errors due to accumulation between the diaphragm and lip of the retainer ring.*
- **BONDED ASSEMBLY INSTALLATION:** Remove the outer O-ring. Unscrew the diaphragm retainer ring by hand or by fitting a hose clamp over the ring and loosen by hand or with pump pliers. Clean face and threads of body. Remove inner O-ring from new assembly and run ring up by hand until diaphragm contacts face (**avoid force**). Magic mark ring opposite arrow on body. Remove ring, install inner O-ring, then thread assembly until ring mark lines up with existing calibration V or dot mark on body. Transmitter is ready to use. Use PMC Field Test Panel for precise calibration.
- **FILTER DISC INFORMATION:** All transmitters are equipped with a filter adapter in the air supply port and gauge port. The air supply filter traps out final traces of dirt and oil that may clog the flow control needle valve. **This filter adapter is not intended as the main line instrument air filter.*** The gauge port filter traps out dirt and metal particles that may originate from the remote gauge connection. The filter discs are sintered from 316 stainless steel particles and have an average pore size of 20 microns (.001"). The standard adapter is chrome plated brass. Stainless adapters are available—see PT-10-SS & PT-12-SS on parts list page 4.
- **REPLACEMENT INFORMATION: Air Supply Port Filter**

In the unplugged state the filter disc will pass 30 x more air than is required to operate the transmitter. If it becomes necessary to open the needle valve beyond 1 turn, the filter disc should be replaced in the following manner:

 - (a) Shut off supply air and disconnect line at air supply port.
 - (b) Remove adapter fitting and push out plugged filter disc with a punch.
 - (c) Insert new disc and drive into place with a clean punch approximately 5/16"(8mm) in diameter.
 - (d) Re-assemble adapter fitting and air supply line. Avoid getting dirt in supply port.

NOTE: Transmitter can be worked on while under pressure without fear of damaging diaphragm.
- * **RECOMMENDED AIR FILTER:** Where clean instrument air is not available we recommend the following filter:
Adjustable Filter Regulator: (1) Norgren B11-221-M2E-W-5203-01 —our part LT-NMFR. This regulator handles four transmitters—two ranges 3-50 psi and 5-125 psi—*please specify range desired.*



PAPER MACHINE COMPONENTS, INC.

EXTRACTOR INSTRUCTIONS

FOR TANK LEVEL TRANSMITTER

IMPORTANT

- Read instructions and study photographs before using extractor.
- Practice full extraction in shop with a spare transmitter before field use.

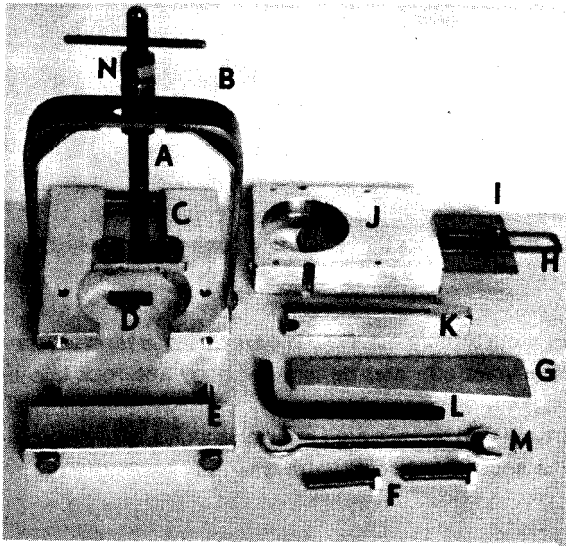

Unassembled Extractor Kit

PART NAME

- A. Extractor Screw
- B. Yoke Assembly
- C. 1/2" Male Connectors
- D. Seal plate for 5/16" set screw
- E. Seal & Lock Assembly
- F. (2) 10-24X1" Gate Assembly Retainer Screws
- G. Aluminum Wedge
- H. Gate Tab
- I. Gate and Stop Pin
- J. Split Gate Assembly
- K. Gate Closing Fork
- L. Allen Wrench for Locking Yoke Assembly Screw
- M. Wrench for F
- N. S/S Stop Nuts

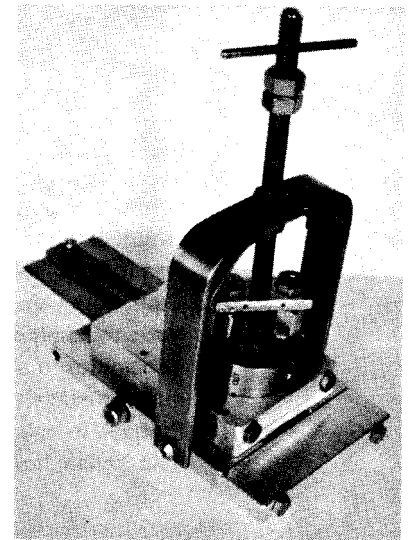

Assembled Extractor. See Step 10

INSTRUCTIONS FOR EXTRACTION

1. Disconnect air supply and gauge port lines from transmitter filter adapters.
2. Remove one 5/16" set screw holding transmitter in place, then install a seal plate over hole.
3. Loosen yoke locking screw, then fit yoke and clamp assembly around nipple and transmitter.
4. Center yoke jaws over the remaining 5/16" set screw. (The seal plate installed in step 2 is held in place by the yoke lock screw.)
5. **Lock** yoke to nipple by **tightening** the screw.
6. Connect extractor screws to filter adapters. Move transmitter down slightly so that the second 5/16" set screw can be removed from the transmitter. (1/2" wrench not supplied)
7. Run two S/S nuts on yoke extractor screw until they touch brass nut on yoke frame and lock together. (This step will provide a positive down stop when re-installing the transmitter.)
8. Replace set screw with seal and lock assembly.
9. Start two 10-24 hex head machine screws on yoke base.
10. Locate split valve body around transmitter with **recessed edge** next to nipple. Gate tab should lie above gate. See assembly photo.
11. Lock valve body together with two hex head screws.
12. Use open end wrench to tighten valve body to yoke base with moderate tension.
13. Extract transmitter through valve body until O-ring appears at the top edge of the body. Close gate with gate closing and opening tool. Tap the tool with a hammer to shear pulp at edge of gate. (When gate is fully home, gate pin will be at the stop.)
14. Remove transmitter for service or exchange.

CAUTIONARY MEASURES

- Pulp in the gate slot may tend to jam the transmitter during re-installation. If so, insert the aluminum wedge between yoke arms and transmitter body and rock body while it is being screwed in.
- Instructions 4 - 6 are **most** important.
- Never allow O-ring to appear too much in the opening of the nipple or the split gate assembly.
- Instruction 15. (**Avoid hydraulic lock**)

RE-INSTALLATION OF TRANSMITTER

15. Clear away pulp and any liquid from above gate to prevent **hydraulic lock** during re-installation.
16. Mount extractor screw fittings to transmitter ports. Move transmitter into split gate assembly slowly until less than half of O-ring is visible.
17. Open gate using gate opening and closing tool.
18. Move transmitter down until S/S nuts on yoke screw contact bronze nut. Pulp in gate slot may tend to jam transmitter. If so, insert aluminum wedge between the yoke arm and transmitter body and rock body during installation.
19. Proceed in reverse through steps 11, 10, 9, 8, then install and tighten set screw and lock washer which hold transmitter in place. Remove yoke and install the second set screw with washer.

PARTS PRICE LIST

| | | |
|----|--|----------|
| B. | Yoke Assembly, complete | \$100.00 |
| E. | Seal and Lock Assembly | 15.00 |
| F. | (2) 10-24X1" Gate Assembly Retainer Screws | 2.00 |
| G. | Aluminum Wedge | 1.00 |
| J. | Split Gate Assembly | 125.00 |
| K. | Gate Closing Fork | 4.00 |
| L. | Allen Wrench for locking Yoke Assembly Screw | 1.50 |
| M. | Wrench for F | 4.00 |

MINIMUM ORDER - \$10.00

MANUFACTURED AND SOLD BY



PAPER MACHINE COMPONENTS, INC.

MIRY BROOK ROAD, DANBURY, CONNECTICUT U.S.A. 06810
TELEPHONE: 203 792 8686

PRINTED IN U.S.A.