

# H6000 & 6100

## Relative Humidity Sensor

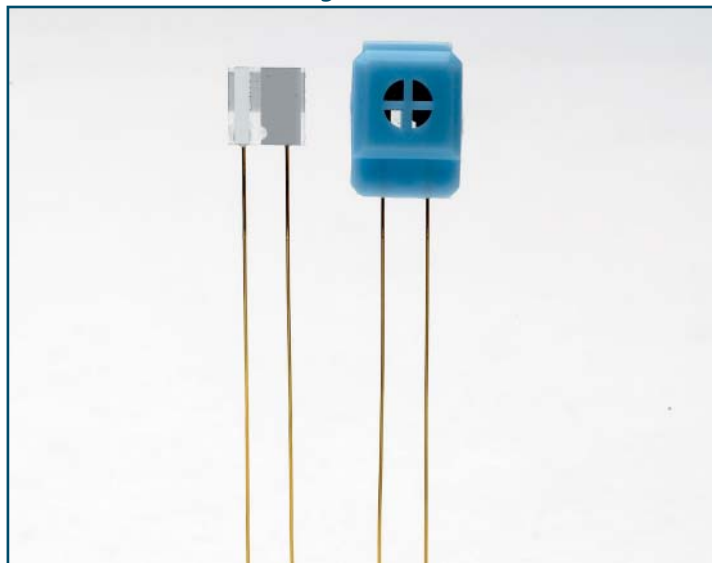

The operating principle of these capacitive relative humidity sensors is based on the hygroscopic properties of a polymer coating, which changes capacitance in response to local RH. The polymer reaches equilibrium with the ambient RH quickly and reversibly, and changes its capacitance value depending on the humidity level.

### Highlights

- Suitable for corrosive atmosphere
- Teflon coating
- Capacitive thin film sensor
- Measuring range: 0–100% RH, Temp: -25 to +390°F / -30 to +200°C
- Mixing ratio: 250g/Kg of dry air
- Low hysteresis
- Response time: 20 seconds

### Dimensions

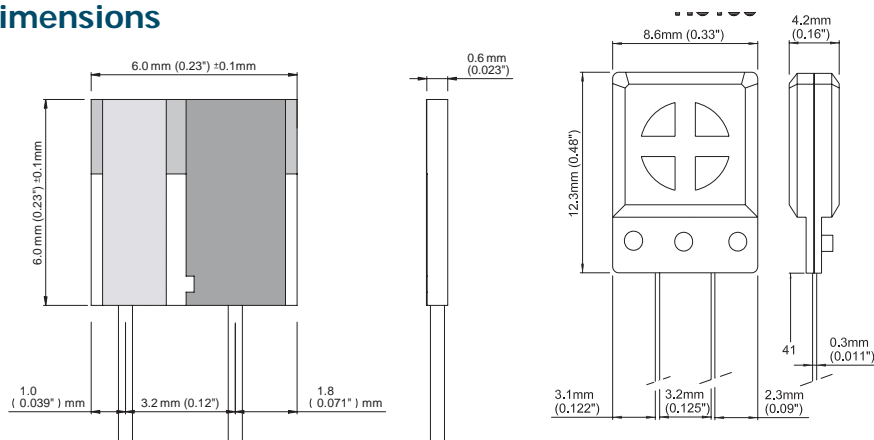

### Technical Specifications

	H6000	H6100
<b>Response time</b> 90% of scale for a step change from 11 to 75% RH	20 sec	20 sec
<b>Operating range</b>		
Humidity	0–100% RH	0–100% RH
Temperature	-30 to +200°C / -22 to +392°F	-30 to +100°C / -22 to +212°F
Pressure	0.04–30 bar / 0.6–400 psi	0.04–30 bar / 0.6–400 psi
<b>Mixing ratio</b>	250g/8.82oz water / Kg dry air	
<b>Nominal capacity</b> 75% RH @ 23°C / 73°F	500 pF ± 10%	
<b>Sensitivity</b> 11–75% RH @ 23°C / 73°F	0.86 pF/% RH	
<b>Linearity</b> 11–90% RH) @ 23°C / 73°F	± 2.5% RH	
<b>Long term stability</b> (12 months) control @ 11% RH	< 1% at 23 °C / 73°F	
<b>Max. air speed</b> (without protection)	< 20m/sec	
<b>Hysteresis</b>	Typical value = 0.5% RH	
<b>D Factor</b> loss tangent @10 KHz 75% RH @ 23°C / 73°F	Typical value = 0.007	
<b>Supply voltage</b> Peak-to-peak	2.5 VAC DC component < 0.2 V	
<b>Operating frequency range</b>	5/300 KHz	
<b>Protection Cap</b>	No	Yes
<b>Weight</b>	0.1g	1g

### Order Codes

H6000	<b>Minimum order 50 pieces</b>
H6100 (with protective cap)	<b>Minimum order 50 pieces</b>

Please note: Michell Instruments adopts a continuous development program which sometimes necessitates specification changes without notice. Please contact us for latest version. Ref: H6000\_1001US\_P

## Effects of pressure, temperature and concentration on humidity parameters

In nature, water exists in three different states: gaseous (vapor), liquid (rain, fog) and solid (snow, ice, hail). Water in the gaseous state is invisible. The maximum quantity of water vapor that the air can contain depends on both temperature and pressure. The table below shows how the parameter change influences the measured values.

Simply stated, relative humidity is the ratio of the actual quantity of water vapor that an air sample contains to the maximum quantity of water vapor that such a sample can contain at the sample pressure and temperature.

	Temperature Increase	Temperature Decrease	Pressure Increase	Pressure Decrease	Vapor Increase	Vapor Decrease
% RH	↓	↑	↑	↓	↑	↓
Dew Point	↔	↔	↑	↓	↑	↓
Absolute Humidity	↔	↔	↑	↓	↑	↓
Mix Ratio	↔	↔	↔	↔	↑	↓
Concentration of Water Vapor	↔	↔	↔	↔	↑	↓

