

ELECTRONIC CLEANER SYSTEM SCHEMATIC

REMOTE CLEANER METER PANEL

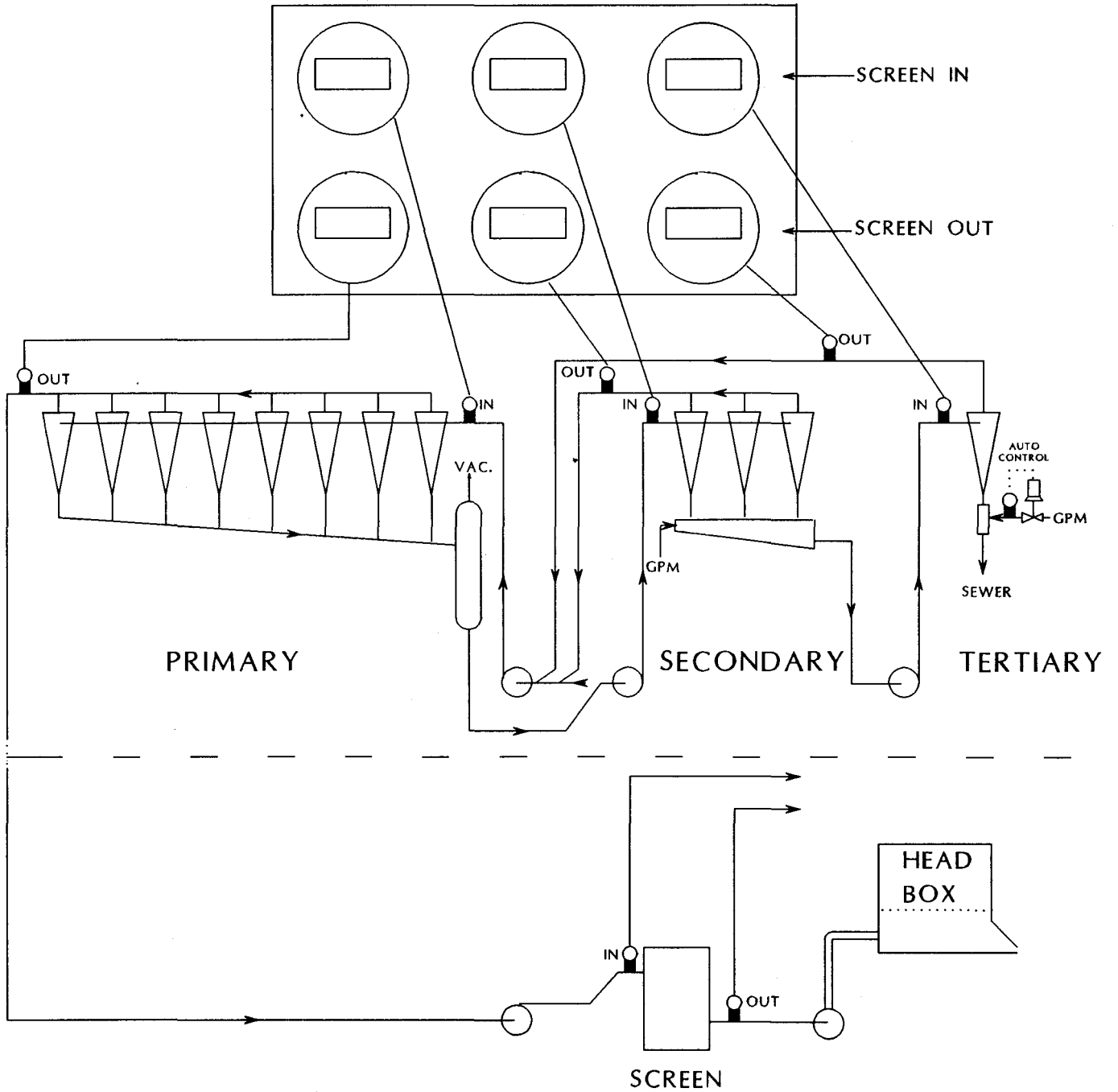

REMOTE CLEANER GAUGE PANEL STANDARD NAMEPLATES

CLEANERS

- | | |
|-------------------------------|--------------------------------|
| 1. PRIMARY SUPPLY PRESSURE | 2. PRIMARY ACCEPTS PRESSURE |
| 3. SECONDARY SUPPLY PRESSURE | 4. SECONDARY ACCEPTS PRESSURE |
| 5. TERTIARY SUPPLY PRESSURE | 6. TERTIARY ACCEPTS PRESSURE |
| 7. QUATERNARY SUPPLY PRESSURE | 8. QUATERNARY ACCEPTS PRESSURE |
| 9. PRIMARY INLET PRESSURE | 10. PRIMARY OUTLET PRESSURE |
| 11. SECONDARY INLET PRESSURE | 12. SECONDARY OUTLET PRESSURE |
| 13. TERTIARY INLET PRESSURE | 14. TERTIARY OUTLET PRESSURE |
| 15. QUATERNARY INLET PRESSURE | 16. QUATERNARY OUTLET PRESSURE |
| 17. PRIMARY CLEANER FEED | 18. PRIMARY CLEANER ACCEPTS |
| 19. SECONDARY CLEANER FEED | 20. SECONDARY CLEANER ACCEPTS |
| 21. TERTIARY CLEANER FEED | 22. TERTIARY CLEANER ACCEPTS |
| 23. QUATERNARY CLEANER FEED | 24. QUATERNARY CLEANER ACCEPTS |
| 25. PRIMARY CLEANER REJECTS | 26. SECONDARY CLEANER REJECTS |
| 27. TERTIARY CLEANER REJECTS | 28. QUATERNARY CLEANER REJECTS |
| 29. PRIMARY FEED | 30. PRIMARY ACCEPTS |
| 31. SECONDARY FEED | 32. SECONDARY ACCEPTS |
| 33. TERTIARY FEED | 34. TERTIARY ACCEPTS |
| 35. QUATERNARY FEED | 36. QUATERNARY ACCEPTS |

PRESSURE SCREENS

- | | |
|----------------------------------|----------------------------------|
| 37. CENTRISCREEN SUPPLY PRESSURE | 38. CENTRISORTER SUPPLY PRESSURE |
| 39. CENTRISCREEN ACCEPT PRESSURE | 40. CENTRISORTER ACCEPT PRESSURE |
| 41. CENTRISCREEN INLET | 42. CENTRISORTER REJECT PRESSURE |
| 43. CENTRISCREEN OUTLET | |

CLEANER HEADERS

- | |
|---|
| 44. PRIMARY INLET PRESSURE FRONT HEADER |
| 45. PRIMARY INLET PRESSURE BACK HEADER |
| 46. SECONDARY INLET PRESSURE FRONT HEADER |
| 47. SECONDARY INLET PRESSURE BACK HEADER |
| 48. PRIMARY CLEANER FEED HEADER |
| 49. SECONDARY CLEANER FEED HEADER |
| 50. TERTIARY CLEANER FEED HEADER |
| 51. QUATERNARY CLEANER FEED HEADER |

CLEANER DILUTION

- | |
|-----------------------------------|
| 52. PRIMARY STOCESAVER DILUTION |
| 53. SECONDARY STOCESAVER DILUTION |
| 54. TERTIARY STOCESAVER DILUTION |

MISCELLANEOUS

- | |
|---------------------------------|
| 55. INLET PRESSURE |
| 56. OUTLET PRESSURE |
| 57. INLET |
| 58. OUTLET |
| 59. SELECTIFIER SUPPLY PRESSURE |
| 60. SELECTIFIER ACCEPT PRESSURE |
| 61. SELECTIFIER INLET PRESSURE |
| 62. SELECTIFIER OUTLET PRESSURE |

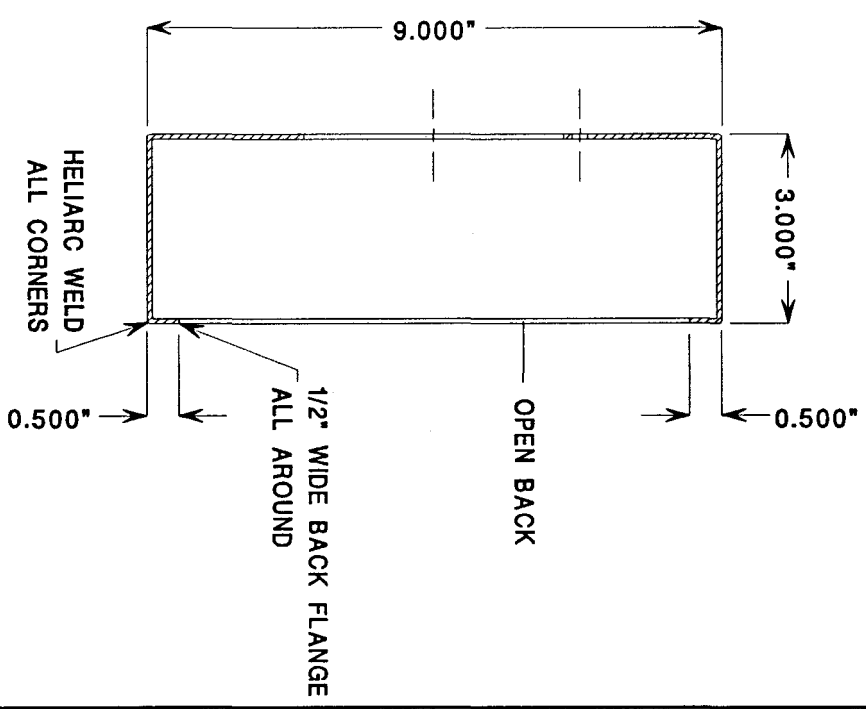
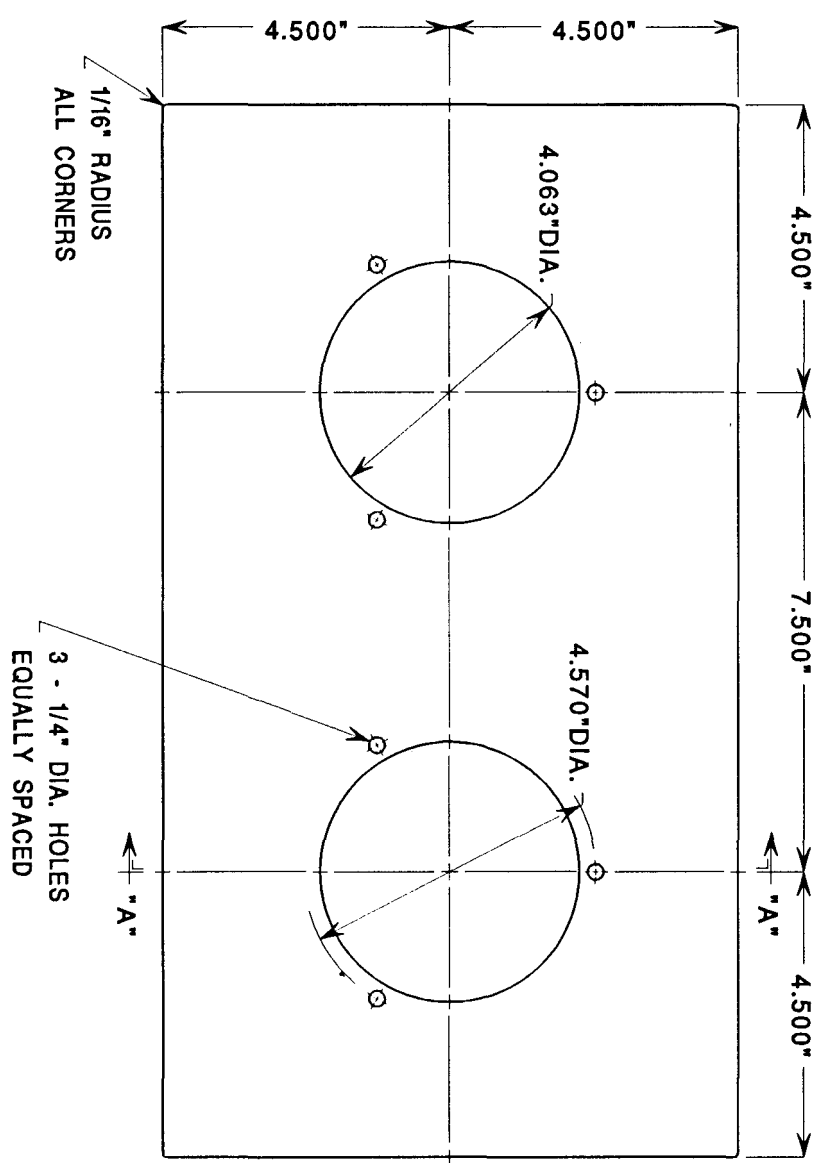

PAPER MACHINE COMPONENTS
DANBURY, CONNECTICUT U.S.A.

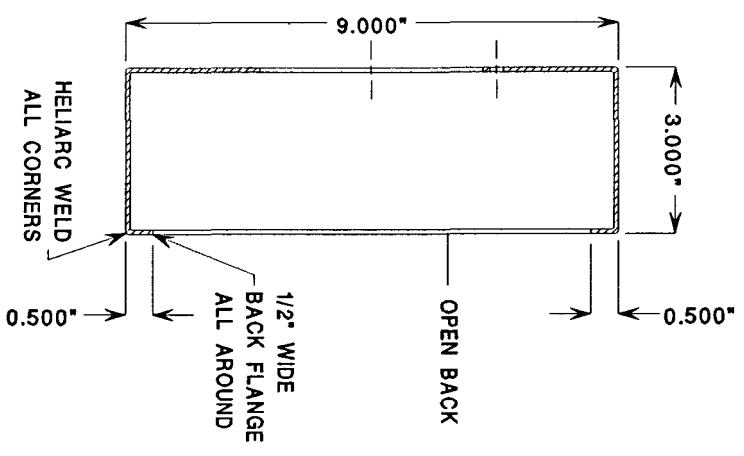
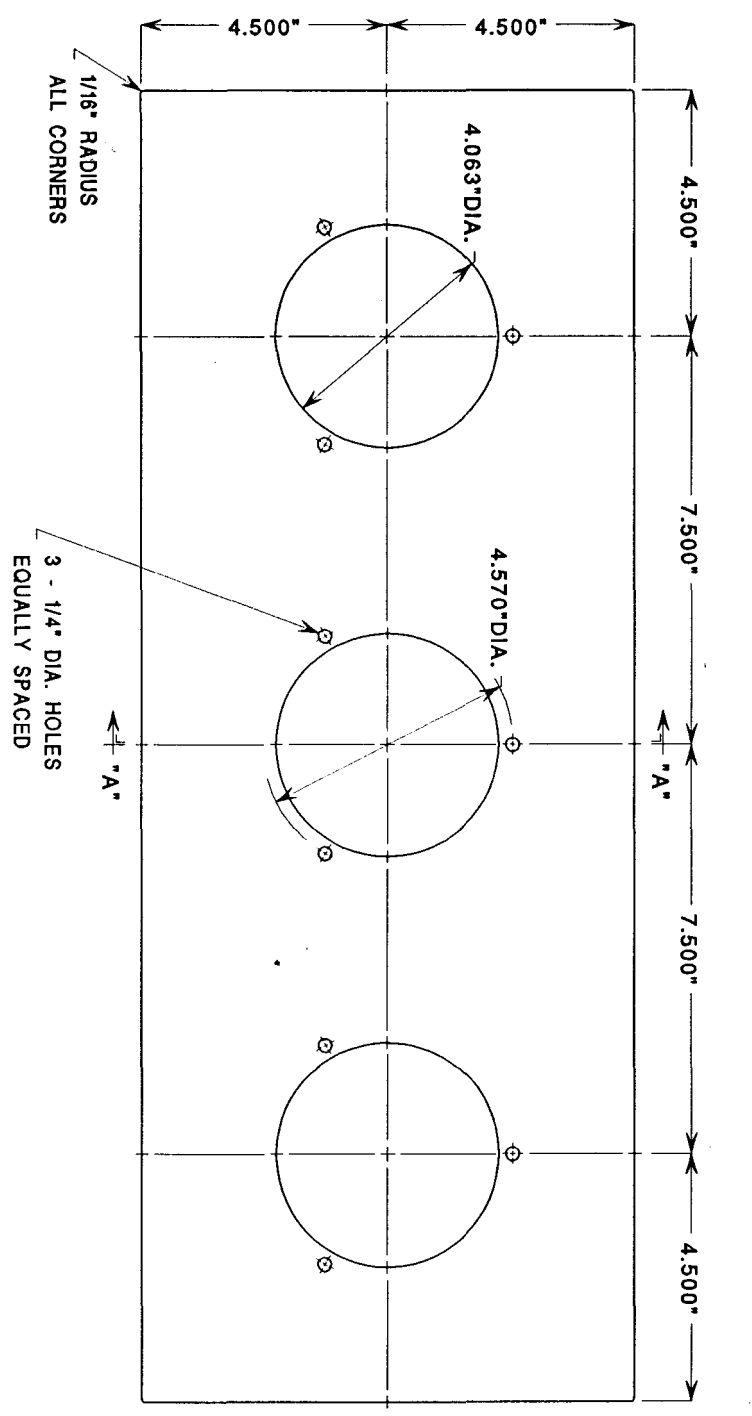

PAPER MACHINE COMPONENTS

DANBURY, CONNECTICUT U.S.A.

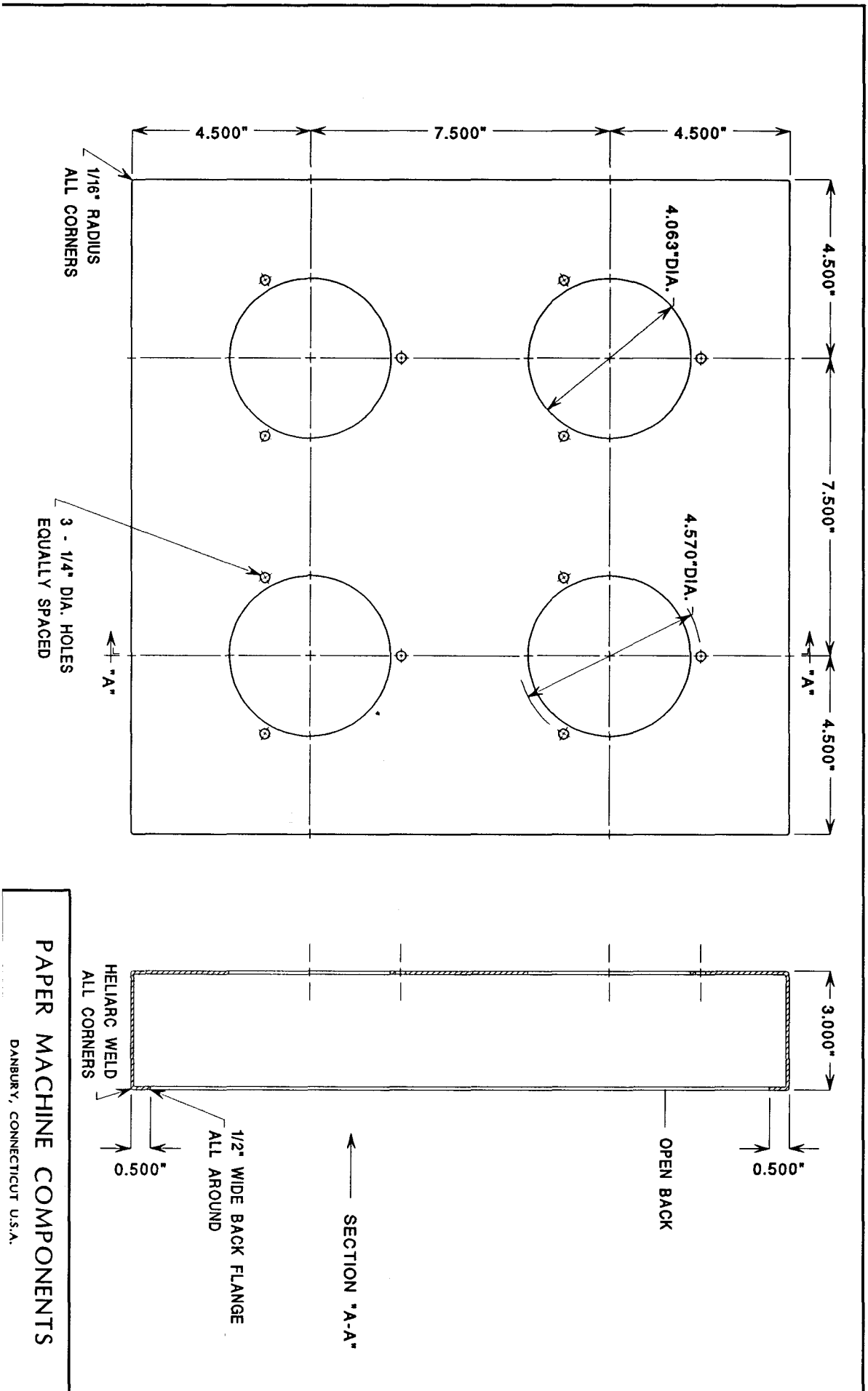

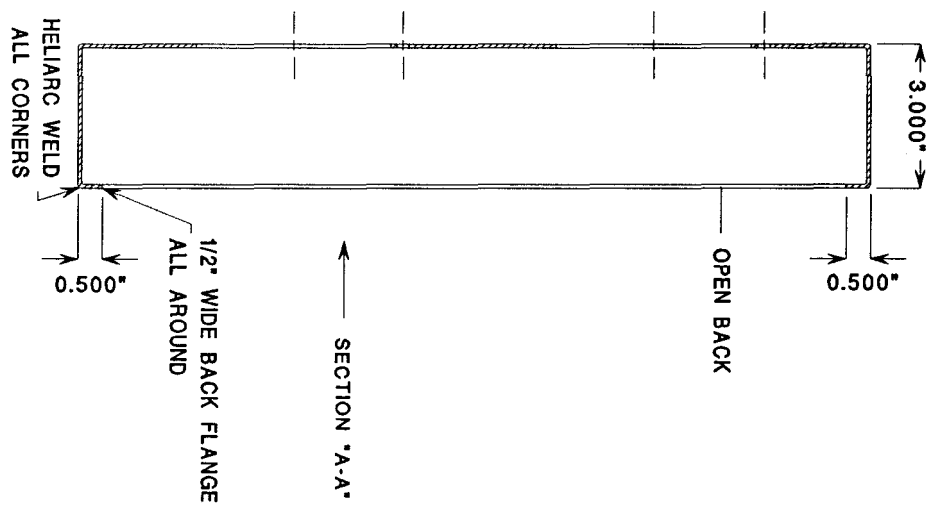
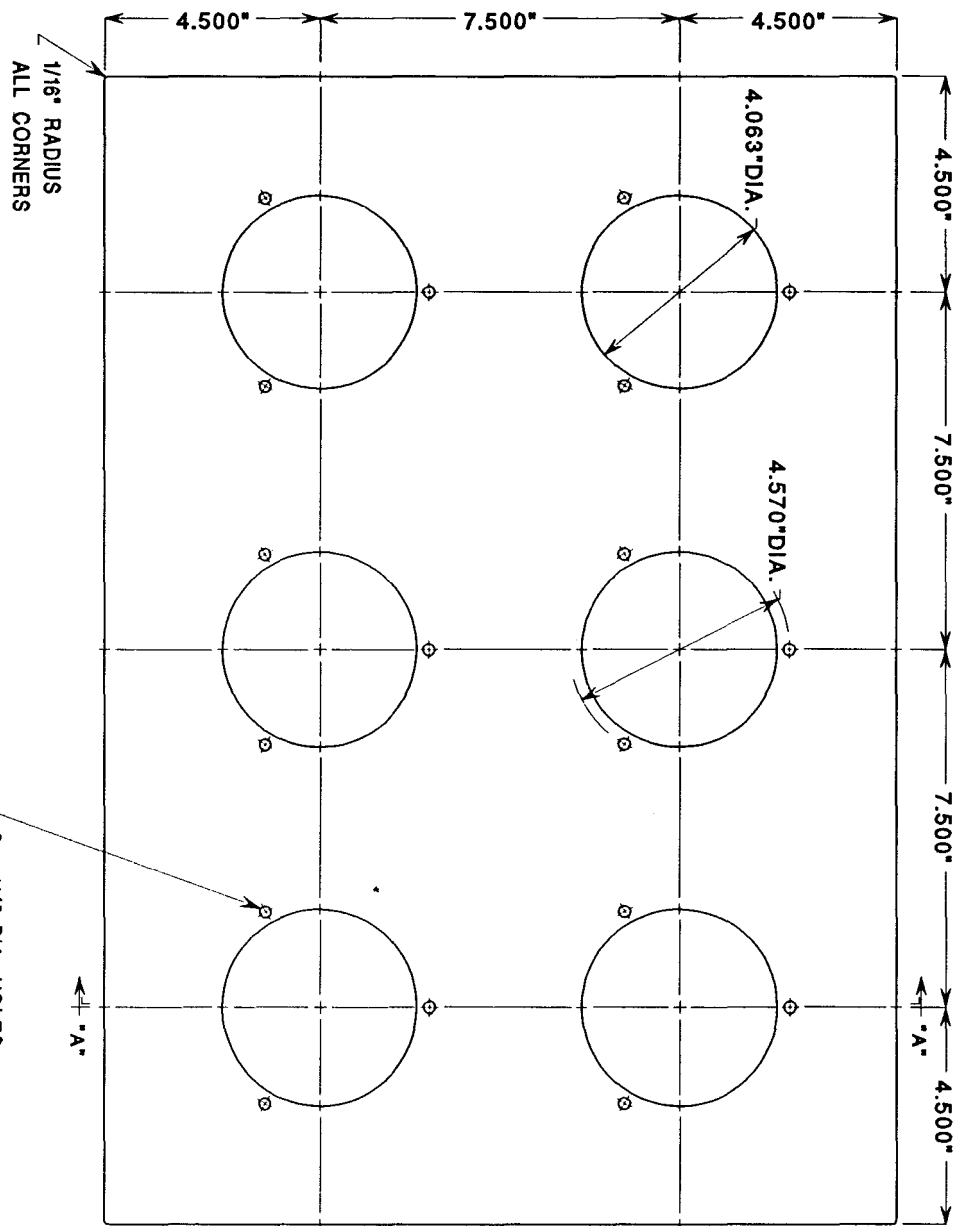

PAPER MACHINE COMPONENTS
 DANBURY, CONNECTICUT U.S.A.

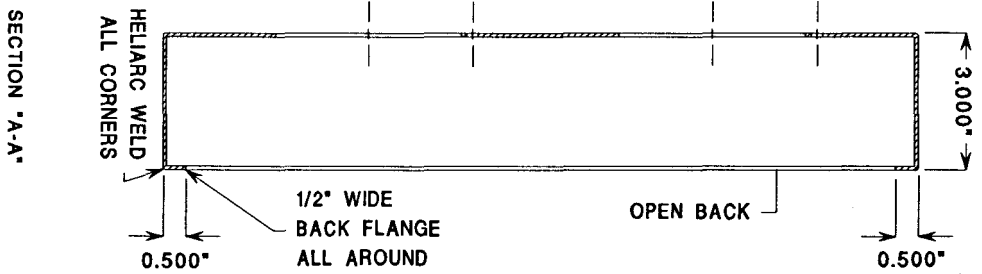
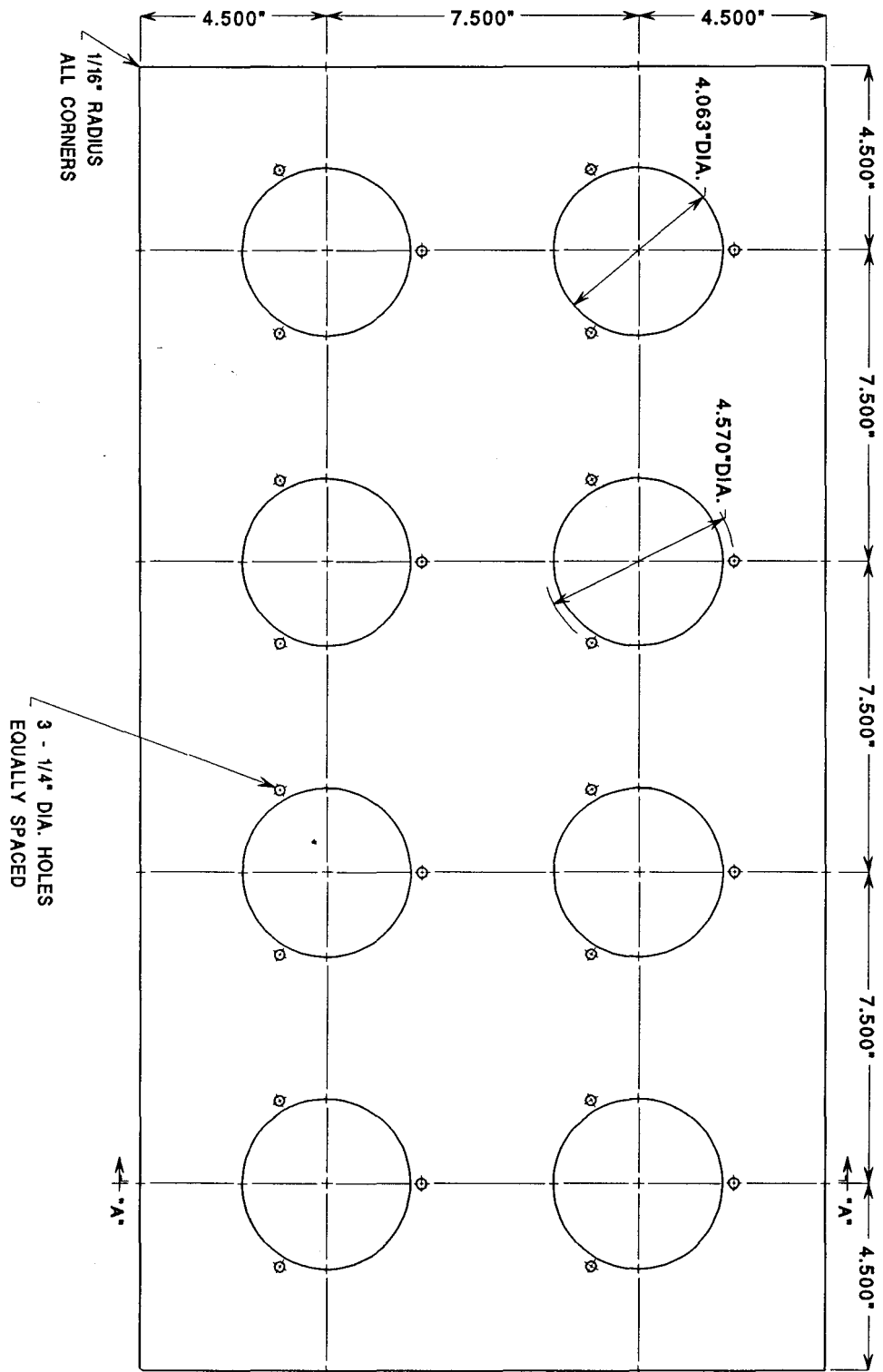

PAPER MACHINE COMPONENTS

DANBURY, CONNECTICUT U.S.A.

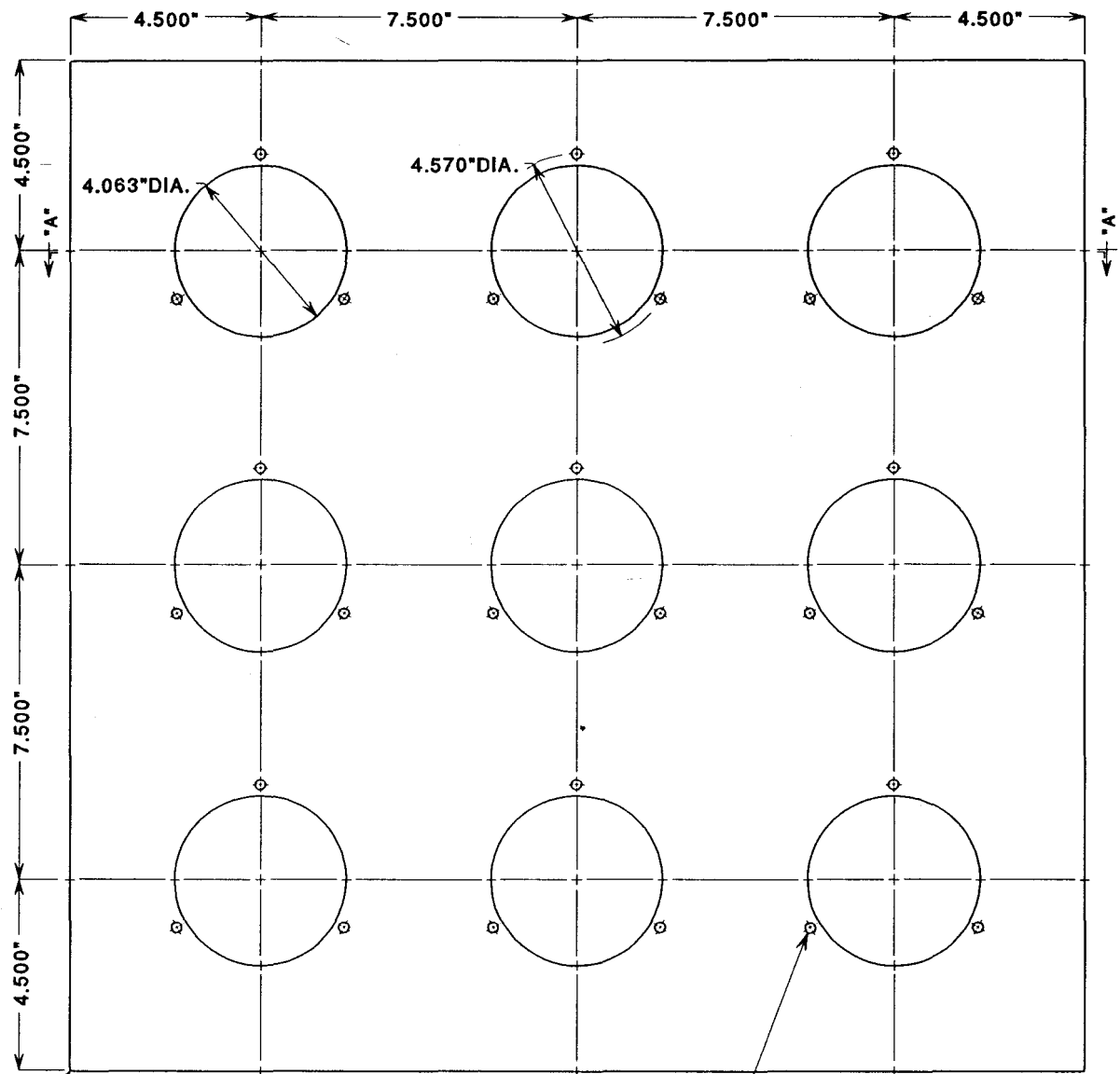

1/16" RADIUS
ALL CORNERS

3 - 1/4" DIA. HOLES
EQUALLY SPACED

HELIARC WELD
ALL CORNERS

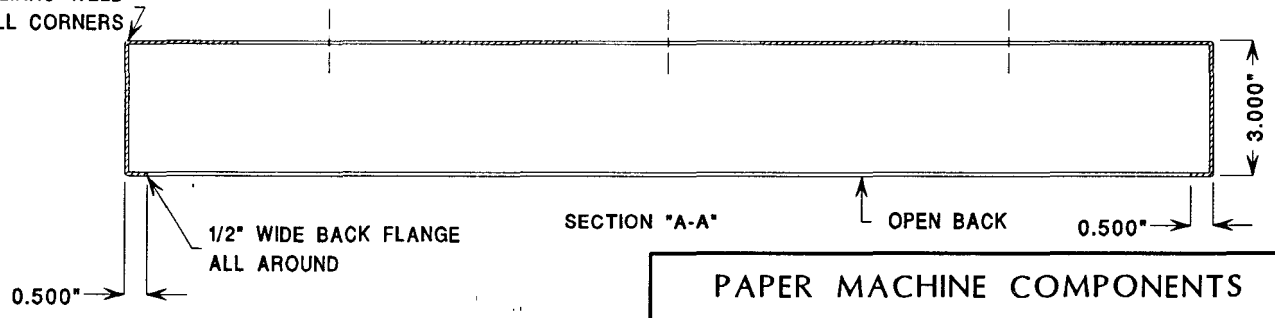

PAPER MACHINE COMPONENTS

DANBURY, CONNECTICUT U.S.A.