

ANALOG VOLTAGE DEPTH/LEVEL TRANSMITTER ATM/N



24

Features

- Fully submersible, 1" diameter
- Accuracy: $\leq \pm 0.1\%$ FS or $\leq \pm 0.25\%$ FS
*Includes linearity, hysteresis, repeatability
AND zero and span settings*
- Ranges 20" WC to 360 psi
- Titanium or 316L SS construction
- Polyurethane cable - PE or FEP option
- Surge (lightning) protection option

Product overview and applications

The ATM/N series 24 is part of a comprehensive range of pressure transmitters specifically designed for the long term monitoring of ground water and waste water. This series 24 provides a range of amplified voltage outputs from 0 - 5 to 0 - 10 VDC. Features such as Kevlar strengthened cable, titanium, ballast weights, data loggers, etc. broaden the installation opportunities. The modular design permits fast delivery for all pressure ranges and standard options.

Examples of applications include:

- Deep wells, lakes, dams and reservoirs
- Bore holes
- Surface water, irrigation canals and rivers
- Waste water and sewage treatment plants
- Tank level measurement

Specification

Measurement

Pressure ranges

Any range from 20" WC to 360 psi FS available, in any engineering units such as psi, Pa, inches H₂O, bar.

Absolute or gauge types available

Proof pressure

FS up to 15 psi: 45 psi
 FS > 15 psi up to 360 psi: 3 x FS, (max. 360 psi)
 Consult factory for higher proof pressure

Operating temperature range

25 to 125°F (standard)
 25 to 175°F (option)

Compensated temperature range

25 to 125°F (standard)
 25 to 175°F (option)

Temperature effects

±1.5% total for 25 to 125°F, > 30 psi FS
 ±2% total for 25 to 125°F, 7 to 30 psi FS
 Prorated for ranges below 7 psi

Performance

Accuracy

Combined linearity, hysteresis, repeatability, Zero and Span set
 ≤ ±0.1% FS (≥ 7 psi FS)
 ≤ ±0.25% FS available

Long term stability

0.1% FS/yr for pressure ranges > 30 psi
 Prorated for ranges below 30 psi
 Under standard conditions

Supply voltage

15 - 30 VDC
 Influence of supply voltage < 0.1% FS

Specification continued

Load resistance

Voltage output: RL > 10kOhm
 Influence of load resistance < 0.1% FS

Output signal

0 to 5 VDC (3-wire)
 0.5 to 4.5 VDC (3-wire)
 1 to 5 VDC (3-wire)
 0 to 10 VDC (3-wire)
 Surge (lighting) protection (option)
 Others available consult factory

Insulation resistance

> 50 megohms @ 500 VDC (@ 68°F)

Response time

< 1ms, 10 to 90% FS

Construction

Pressure media compatibility

Stainless steel 316L, Viton seals
 Other seal materials available
 Titanium version available

Pressure connection

Closed (Fig. 1) POM nose cone (supplied as standard)
 Open (Fig. 2) POM nose cone with ø0.59" opening available as option
 Other connections available

Electrical connection

Polyurethane, polyethylene or FEP cable
 Fixed or field replaceable version (Fig. 3) available

Specification continued

Weight

6 oz approximate (not including cable)

Vibration

10 g, 10 to 2000 Hz

Mechanical shock

100 g / 6 ms

Ordering information

Please specify the following:

- 1) Model number - ATM/N 24
 - 2) Electrical connection
 - 15 - Polyurethane cable
 - 13 - Polyethylene cable
 - 21 - FEP cable
 - 3) Pressure range, including eng. units, type
 - 4) Accuracy
 - 5) Output signal
 - 6) Cable length
 - 7) Any special feature: i.e. lightning protection
- Example ordering format:
 ATM/N 24 - 15 - 10 psig - 0.1% - 0 - 5 VDC - 20 feet cable

Options

STS offers a wide range of options for these and other similar transmitters. Please consult the factory for any special requirements.

Examples include:

- Alternate electrical configurations i.e. 0 to 20 mA, 4 to 20 mA, RS 485
- Lightning protection
- Intrinsic safety certification
- Special oil filling for food application etc.
- Alternate construction i.e titanium
- Alternate seals i.e. EPDM, Kalrez
- Wide range of pressure connectors
- Wide range of electrical connectors
- Datalogging

Dimensions (inches)

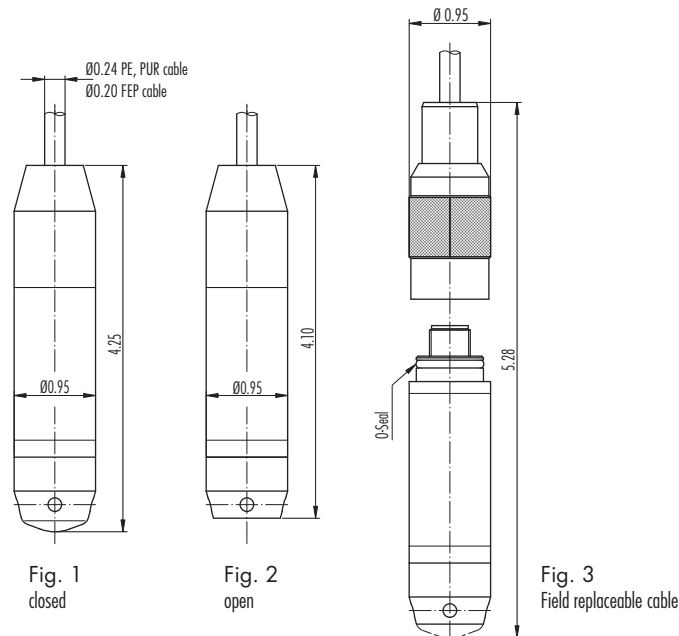

Specifications may change without notice.

STS is registered ISO 9001:2008

10.00.0218.C - 305



PMC-STs, Inc.
 11 Old Sugar Hollow
 Road Danbury, CT
 06810 U.S.A

Tel: 203-792-8686
 Fax: 203-743-2051
 sales@pmc1.com
 www.pmc1.com

Represented by: